



Frankfurter Strasse 142-190
D - 51065 Köln
Tel: (02 21)6 99 98-0 Fax: (02 21)69 71 21
Telex: 8 873 423

Technical Sheet 29E



7 Bronze Road, Spartan Ext 16, Kempton Park
P.O.Box 689, Edenvale, 1610, South Africa
Tel: +27 11 974-1004 Fax: +27 11 392-5650

Crane Stop Buffers of ACLACELL® / AUTAN®

Buffers of polyurethane

Crane Stop Buffers of the high grade polyurethane elastomers ACLACELL / AUTAN have a mixed cellular structure and are distinguished by the following outstanding properties in practical life:

- easy assembly
- high energy absorption with small volume (low weight)
- important compressibility
- high specific surface pressure
- no risk of breakage (no limit stop compared with steel springs)
- excellent noise damping also with hardest shocks
- gentle impact
- the profiled upper surface enables a clean fixation of the counterpressure surface
- good oil resistance
- temperature range from -20°C to $+80^{\circ}\text{C}$ (from -4°F to $+176^{\circ}\text{F}$)

On account of the excellent properties the ACLA buffers are mainly used in crane construction and as safety buffers for extremely high shock loads.

Standard program and special types

The article range overleaf shows the standard program of ACLA-WERKE for crane stop buffers. Special types, e.g. buffer batteries are available on request.

In case of extreme applications (e.g. outside with changing weather conditions) a surface protection is recommended consisting of a sprayed skin of ACLATHAN S in order to protect the cellular material structure.

For special applications buffers with central safety rope can be supplied (from dia. 250mm on). As to sizes up to dia. 250mm we refer to our Technical Sheets 66 E featuring safety buffers as supplementary program with central thread bolt or nut.

Buffer type C with rectangular steel plate

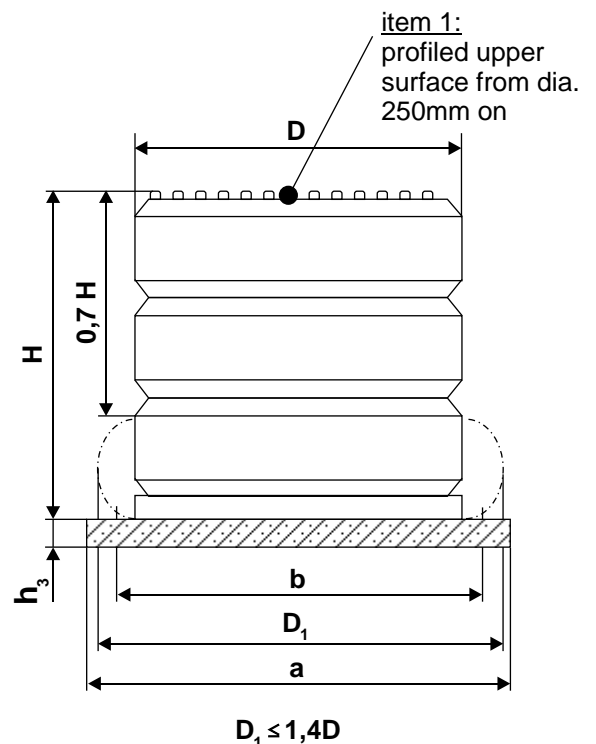

Rectangular Steel Plate

4 fixing holes preferably for cheese-head screws DIN 6912 or DIN 6984

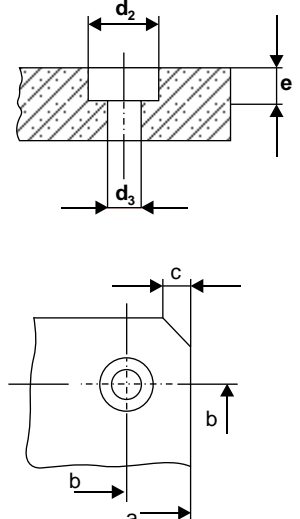



Technical Sheet 29E

| Buffer Dimensions | | | | | | | | | Art. no. for type C | Buffer weight (ca.) for type C (kg) | Energy absorption Reaction in Nm in kN | | | | |
|-------------------|-----|----------------|-----|-----|----|----------------|----------------|---|---------------------------|---|--|-----------------|----------------|----------------|----------------|
| D | H | h ₃ | a | b | c | d ₂ | d ₃ | e | | | with v in m/s | | | | |
| | | | | | | | | | | | nearly static | 1 | 2 | 3 | 4 |
| 100 | 80 | 6 | 130 | 100 | | | 14 | | 300 421 | 1,3 | 250 46 | 350 40 | 500 40 | 750 55 | 1250 76 |
| 125 | 80 | 6 | 155 | 125 | | | 14 | | 300 422 | 2,0 | 400 70 | 600 60 | 800 60 | 1200 81 | 2000 115 |
| 165 | 80 | 6 | 205 | 165 | | | 18 | | 300 423 | 4,1 | 800 140 | 1200 120 | 1600 120 | 2400 163 | 4000 230 |
| 220 | 80 | 6 | 260 | 220 | | | 18 | | 300 424 | 6,8 | 1250 230 | 1850 200 | 2500 200 | 3750 270 | 6250 385 |
| 100 | 160 | 6 | 130 | 100 | | | 14 | | 300 425 | 1,6 | 500 46 | 680 40 | 950 40 | 1450 55 | 2350 76 |
| 125 | 160 | 6 | 155 | 125 | | | 14 | | 300 426 | 2,4 | 800 70 | 1100 60 | 1500 60 | 2300 81 | 3700 115 |
| 165 | 160 | 6 | 205 | 165 | | | 18 | | 300 427 | 4,9 | 1400 140 | 2000 120 | 2700 120 | 4100 163 | 6700 230 |
| 220 | 160 | 6 | 260 | 220 | | | 18 | | 300 428 | 8,3 | 2400 230 | 3300 200 | 4500 200 | 6900 270 | 1100 385 |
| 140 | 250 | 6 | 180 | 140 | | | 18 | | 300 429 | 4,4 | 1850 100 | 2500 85 | 3500 85 | 5300 120 | 8800 170 |
| 180 | 280 | 6 | 220 | 180 | | | 18 | | 300 379 | 7,4 | 3100 150 | 4300 130 | 6000 130 | 9100 175 | 15000 250 |
| 250 | 130 | 12 | 320 | 250 | 15 | 34 | 22 | 6 | 300 136 | 15,2 | 3800 270 | 5500 240 | 7500 240 | 12000 335 | 20000 470 |
| 250 | 250 | 12 | 320 | 250 | 15 | 34 | 22 | 6 | 300 056 | 20,0 | 7900 270 | 11000 240 | 15000 240 | 24000 335 | 39000 470 |
| 250 | 380 | 12 | 320 | 250 | 15 | 34 | 22 | 6 | 300 064 | 23,5 | 11500 270 | 16500 240 | 23000 240 | 35500 335 | 58000 470 |
| 315 | 160 | 15 | 400 | 315 | 40 | 34 | 22 | 6 | 300 099 | 30,0 | 7500 410 | 11000 380 | 15000 380 | 24000 500 | 40000 700 |
| 315 | 320 | 15 | 400 | 315 | 40 | 34 | 22 | 6 | 300 062 | 36,5 | 15000 410 | 22000 380 | 31000 380 | 47000 500 | 77000 700 |
| 315 | 480 | 15 | 400 | 315 | 40 | 34 | 22 | 6 | 300 065 | 43,5 | 23000 410 | 33000 380 | 46000 380 | 71000 500 | 117000 700 |
| 400 | 200 | 20 | 506 | 400 | 50 | 39 | 26 | 8 | 300 110 | 57,0 | 15000 670 | 22000 620 | 30000 620 | 47000 840 | 78000 1170 |
| 400 | 400 | 20 | 506 | 400 | 50 | 39 | 26 | 8 | 300 061 | 71,0 | 30000 670 | 43000 620 | 59000 620 | 94000 840 | 155000 1170 |
| 400 | 600 | 20 | 506 | 400 | 50 | 39 | 26 | 8 | 300 057 | 85,0 | 45000 670 | 65000 620 | 93000 620 | 142000 840 | 230000 1170 |
| 500 | 250 | 20 | 638 | 500 | 60 | 39 | 26 | 8 | 300 133 | 95,0 | 33000 900 | 47000 850 | 65000 850 | 107000 1120 | 173000 1570 |
| 500 | 500 | 20 | 638 | 500 | 60 | 39 | 26 | 8 | 300 058 | 121,0 | 67000 900 | 97000 850 | 137000 850 | 214000 1120 | 350000 1570 |
| 500 | 750 | 20 | 638 | 500 | 60 | 39 | 26 | 8 | 300 059 | 147,0 | 93000 900 | 133000 850 | 180000 850 | 280000 1120 | 460000 1570 |
| 600 | 300 | 25 | 738 | 600 | 60 | 39 | 26 | 8 | 300 134 | 134,0 | 45000 1500 | 68000 1400 | 95000 1400 | 152000 1870 | 250000 2640 |
| 600 | 620 | 25 | 738 | 600 | 60 | 39 | 26 | 8 | 300 067 | 182,0 | 100000 1500 | 145000 1400 | 200000 1400 | 320000 1870 | 520000 2640 |
| 600 | 900 | 25 | 738 | 600 | 60 | 39 | 26 | 8 | 300 135 | 224,0 | 150000 1500 | 220 000 1400 | 300000 1400 | 480000 1870 | 720000 2640 |

Dimensions in mm. We reserve the right to change sizes. Further dimensions and special types on request.

Our verbal or written recommendations for any

application as well as tests are carried out to the best of our knowledge. They are without engagement also as far as patent rights of third parties are concerned, and do not exempt you from checking the products supplied by us to their

suitability for the intended procedure and purpose. Application, use and processing of the products are outside our control, and are exclusively the responsibility of the customer. Moreover our general sales conditions apply.